

RTRI *Series*



MECCANICHE LODI

Passion for Grinding



 Compatte e robuste, le rettificatrici tangenziali a tavola rotante della serie RTRI sono il risultato di importanti studi e test effettuati dal settore Ricerca e Sviluppo della Meccaniche Lodi. I criteri progettuali ed i dispositivi adottati, per adeguare tutti i particolari alla robusta struttura, permettono di raggiungere grande capacità di asportazione unita ad una eccellente precisione ed una finitura superficiale accurata. Questi modelli sono rivolti principalmente ai settori della produzione di corpi mandrino, supporti per cuscinetti, anelli e in assoluto ovunque sia indispensabile raggiungere precisioni estreme in tempi di lavoro ridotti.

 *Stiff and stout, the Rotary Table Surface Grinders of RTRI series are the result of important studies and tests made by Meccaniche Lodi's Research and Development Department. The design selection and the used devices, to gear all small components to the stout frame, allow to get high removal capacity along with an excellent accuracy and an accurate surface finishing. These models are mainly suitable for grinding of spindle housings, bearing holders, rings and wherever it is a must to get extreme accuracy in reduced working time.*

 Diese kompakten und robust gebauten Rundtisch-Flachschleifmaschinen der Baureihe RTRI sind das Ergebnis maßgeblicher Studien und Tests, die die Forschungs- und Entwicklungsabteilung der Firma Meccaniche Lodi durchgeführt hat. Sowohl Projektkriterien als auch Vorrichtungen zum Anpassen aller Komponenten an die robuste Struktur gestatten eine hohe Abtragsleistung bei höchster Präzision und erstklassiger Oberflächenbehandlung. Die Modelle sind in erster Linie für die Serienproduktion von Spindelgehäusen, Lagerhaltern, Ringen und ganz allgemein für diejenigen Bereiche gedacht, in denen allerhöchste Präzision und kurze Bearbeitungszeiten gefordert sind.



RTRI Series





RTRI Series



MECCANICHE LODI

RTRI

Diametro rettificabile / Grinding diameter / Schleifdurchmesser	mm	da/from/von 500 a/to/bis 2000
Diametro tavola rotante / Rotary table diameter / Durchmesser rundtisch	mm	da/from/von 500 a/to/bis 2000
Altezza rettificabile standard / Standard grinding height / Standardschleifhöhe	mm	da/from/von 400 a/to/bis 1200
Incremento automatico / Automatic increment / Automatische zustellung	mm	0.0005
Potenza mandrino / Spindle motor / Spindelantrieb	kW	da/from/von 15 a/to/bis 63

Le caratteristiche tecniche e le immagini non sono impegnative. Ci riserviamo il diritto di apportare senza preavviso tutte le variazioni che riterremo opportune.

Technical features and pictures are not binding. We reserve the right to modify them without any prior notice.

Die bezeichnete technische Daten sind nicht verbindlich. Wir behalten uns Recht vor, dieselbe ohne Voranzeige zu ändern.

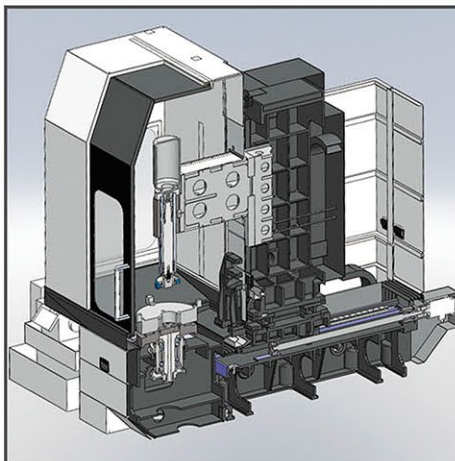

 Le esperienze fatte con la progettazione e la costruzione di rettificatrici speciali hanno condizionato le scelte tecniche e le soluzioni che permettono oggi alle nostre nuove rettificatrici di affrontare la concorrenza internazionale e le crescenti esigenze dei clienti con la consapevolezza che i principali fattori competitivi sono la qualità e l'affidabilità del prodotto.

 *The several experiences made in the design of special grinders have influenced the choices and solutions which allow nowadays the new grinding machines to face the international competition and meet the requests of more and more demanding customers. All is made with the consciousness that the main competitive factors are quality and reliability of the product.*

 Die lange Erfahrung mit der Konstruktion und mit der Fertigung von Spezial-Schleifmaschinen haben positiv unsere technischen Entscheidungen beeinflusst. Diese erlauben heute unseren Schleifmaschinen die internationale Konkurrenz und den wachsenden Bedarf der Kunden gegenüberzutreten mit dem Bewusstsein, dass heutzutage nur noch die Qualität und die Zuverlässigkeit des Produktes die einzigen Wettbewerbsfaktoren sein können.

... all'operazione di rettifica è affidato il compito di garantire ottimi risultati in finitura superficiale, in rugosità e in precisione. Quindi "l'esito qualitativo della produzione".



MECCANICHE LODI

NUOVE MECCANICHE LODI S.r.l.

Sede Legale: Via G. Baretti, 1 - 20122 MILANO - ITALY

Sede Operativa: Via San Giovanni, 109 - 27029 VIGEVANO (PV) - ITALY

Phone: +39 0381988022 - Fax: + 39 0381988023

www.meccanichelodi.com - info@meccanichelodi.com